



Acousto-Optic Modulator Driver

Including: Basic Modulator Alignment

Instruction Manual

RJ5-40, RJ5-50, RJ5-80 Series

(Formerly RFJ040, RFJ050, RFJ080 series)

Models -

RJ5-40-15 : 40MHz, >12W output
RJ5-40-25 : 40MHz, >20W output

RJ5-50-15 : 50MHz, >12W output
RJ5-50-25 : 50MHz, >20W output

RJ5-80-15 : 80MHz, >12W output
RJ5-80-25 : 80MHz, >20W output

Standard : 0-1V analog modulation range, active low RF gate

Options -x:

- V : 0-5V analog modulation range, active low RF gate
- X : 0-10V analog modulation range, active low RF gate
- D : Digital modulation, active low RF gate
- DA : Both digital and analog modulation (no RF gate)

ISOMET CORP, 10342 Battleview Parkway, Manassas, VA 20109, USA.

Tel: (703) 321 8301, Fax: (703) 321 8546, e-mail: isomet@isomet.com

www.ISOMET.com

ISOMET (UK) Ltd, 18 Llantarnam Park, Cwmbran, Torfaen, NP44 3AX, UK.

Tel: +44 1633-872721, Fax: +44 1633 874678, e-mail: isomet@isomet.co.uk



1. GENERAL

The RJ5- combined Driver and Power Amplifiers are fixed frequency RF power sources specifically designed to operate with Isomet acousto-optic devices such as the M1133-aQ and M1377aQ series. The driver accepts independent digital and/or analogue modulating signals and provides a double-sideband amplitude modulated RF output to the acousto-optic modulator. A summary of the driver specification is shown in the following table:

<u>Model</u>	<u>Amod</u>	<u>Center Frequency</u>	<u>Output Power</u>
RJ5-40-15	1V	40MHz	> 12.0 Watt
RJ5-50-25-X	10V	50MHz	> 20.0 Watt
RJ5-80-15-V	5V	80MHz	> 12.0 Watt
RJ5-80-25	1V	80MHz	> 20.0 Watt

Figure 2 is a functional block diagram of the driver. The center frequency of the driver is determined by the free-running quartz-crystal oscillator at 40MHz, 50MHz or 80MHz resp'. This frequency is accurate to within ± 25 ppm and its stability is better than ± 25 ppm; the oscillator is not temperature stabilized.

The RJ5 series feature three possible control inputs; Amod , Dmod and -GATE

Amod (Fast)

A high-frequency, diode ring modulator is used to apply proportional control (a.k.a. analog modulation). Depending on the model, an input voltage swing of 1V (5V or 10V)* peak will result in 100% depth of amplitude modulation.

Dmod (Fast)

A further high speed solid state switch provides the Digital Modulation or RF Gating function.

The input is 5V logic compatible

Logic High = ON

Logic Low = OFF



-GATE (Slow)

This input provides a gating function and is inverse logic, 5V compatible

Logic High or no connect = OFF

Logic Low = ON

On Power Level

The 'ON' output RF power level is defined by the applied **Amod** input voltage. The input range is model dependent ; Amod range = 0-1V is standard. Options -V = 0-5V, -X = 0-10V. The multi-turn **PWR ADJ** potentiometer provides gain control and sets the maximum RF output power when Amod is at its maximum level e.g. 1V

Amod: proportional analog input. The input level must not exceed 2x the model specific Amod rating * (See Driver test data sheet).

Dmod/GATE: digital logic inputs Level must not exceed 5.5 volts

The rise and fall times for the amplifier from either modulation input is identical (approx' 150nsec rise, 50nsec fall) at full power.

This amplifier is designed to operate at full rated power into a 50Ω load with 100% duty cycle.

The output power level is set by a multi-turn potentiometer (PWR ADJ)

NOTE : Maximum power = fully clockwise

Mounting the driver to heat conducting surface is mandatory.

The heatsink temperature must not exceed 50°C.

An internal sensor will disable the driver when the temperature exceeds 50degC

**SERIOUS DAMAGE TO THE AMPLIFIER MAY RESULT IF THE TEMPERATURE EXCEEDS 70°C.
SERIOUS DAMAGE TO THE AMPLIFIER MAY ALSO RESULT IF THE RF OUTPUT CONNECTOR IS OPERATED OPEN-CIRCUITED OR SHORT-CIRCUITED.**

A low impedance DC power supply is required. The operating voltage is +24V or +28Vdc at a current drain of approximately 3A. The external power source should be regulated to ± 2% and the power supply ripple voltage should be less than 200mV for best results.

Higher RF output power is achieved at 28Vdc.

Figures 3 and 5 show the main AO modulator parameters

2 LED INDICATORS

The front panel LEDs serve to indicate a number of possible operating states.

The LEDs [C] and [D] illuminate when the DC power is applied and the Interlocks are valid.



- [A] shows RED when the (thermal) Interlocks are enabled
- [B] shows YELLOW when the RF power amplifiers are Gated On (Dmod =Logic High)
- [C] shows GREEN when DC power is applied

LEDs Off

The LED [A] will not illuminate if :

- a) the internal driver thermal interlock switch is open (Over temperature fault)
- b) the AOM thermal interlock switch is open (Over temperature fault)
- c) the AOM thermal interlock is not connected to the driver interlock input
- d) the DC supply is off.

The LED [B] may not illuminate or run dim if :

- a) the D Mod input is operating at low duty cycle
- b) the D Mod is not active (logic low)
- c) the DC supply is off.

The thermal interlocks will reset once the AO device and / or RF driver are cooled below the switching temperature.

- The driver thermal switch over temperature trip point is 50deg C
- The typical AOM thermal switch over temperature trip point is 50deg C

The hysteresis of the thermal switch is 7-10deg C.

Once in a fault state the coolant temperature may need to be reduced to reset the thermal switches.



3. INSTALLATION AND ADJUSTMENT

Refer figure 4, 5 and Appendix A

- 3.1 Mount the driver and AO device to suitable heat conducting surfaces.

Due to the high RF power dissipated in the AO modulator, it is paramount that the devices are mounted to a heatsink.

- 3.2 With no d-c power applied, connect the + 24V (or +28V) DC to the screw terminal.
DO NOT APPLY POWER.

- 3.3 Connect the RF output BNC jack to the acousto-optic modulator (or a 50Ω RF load, if it is desired to measure the modulator RF output power).

- 3.4 Connect the Interlock of the acousto-optic modulator (SMA, SMC, 3pin snap-in connector or 2 pin molex) to the 3-pin snap INT connector on the RF driver (Binder connector, pins1 and 2).

The interlock connection becomes open circuit disabling the RF output, if the temperature of the modulator exceeds 50°C or the internal driver temperature exceeds 50°C.

- 3.5 Adjustment of the RF output power is best done with amplifier connected to the acousto-optic modulator. The Amplifier maximum output power is factory preset to approx' 10W.

The optimum RF power level required for the modulator to produce maximum first order intensity will be different at various laser wavelengths. Applying RF power in excess of this optimum level will cause a decrease in first order intensity (a false indication of insufficient RF power) and makes accurate Bragg alignment difficult. It is therefore recommended that initial alignment be performed at a low RF power level.

Please refer to the AOM and RF driver test data sheets for RF power settings

- 3.6 Locate the PWR ADJ access on the driver end plate.

- 3.7 With an insulated alignment tool or screwdriver rotate the PWR ADJ potentiometer fully anti-clockwise (at least 10 turns CCW) , then clockwise (CW) approx 4 turns.



3.8 Apply DC to the amplifier.

3.9 Apply a 1.0V (5V or 10V)* constant modulation signal to the SMA input **A Mod**.

3.9.1 Apply a constant logic high level to the to the SMA input **D Mod**.

Input the laser beam toward the centre of either aperture of the AOM/AOQ. Ensure the laser polarization is correct for the AOM model and the beam height does not exceed the active aperture height of the AOM.

Start with the laser beam normal to the input optical face of the AOM and very slowly rotate the AOM (either direction). See Figure 4 below for one possible configuration.

3.10 Observe the diffracted first-order output from the acousto-optic modulator and the undeflected zeroth order beam. Adjust the Bragg angle (rotate the modulator) to maximise first order beam intensity.

3.11 After Bragg angle has been optimized, slowly increase the RF power (rotate PWR ADJ CW) until maximum first order intensity is obtained.

3.12 The driver is now ready for use for modulation using both the digital and the analog inputs.

* Amod input voltage is model dependent 0-1V standard, Options -V = 0-5V, -X = 0-10V



4. MAINTENANCE

4.1 Cleaning

It is of utmost importance that the optical apertures of the AO device be kept clean and free of contamination. When the device is not in use, the cover apertures may be protected by kapton tape.

It will probably be necessary in time to wipe the coated window surfaces of atmospherically deposited films. Although the coatings are hard and durable, care must be taken to avoid gouging of the surface and leaving residues. It is suggested that the coatings be wiped with a soft ball of brushed (short fibres removed) cotton, slightly moistened with clean alcohol. Before the alcohol has had time to dry on the surface, wipe again with dry cotton in a smooth, continuous stroke. Examine the surface for residue and, if necessary, repeat the cleaning.

4.2 Troubleshooting

No troubleshooting procedures are proposed other than a check of alignment and operating procedure. If difficulties arise, take note of the symptoms and contact the manufacturer.

4.3 Repairs

In the event of malfunction, discontinue operation and immediately contact the manufacturer or representative. Due to the high sensitivity of RF tuning procedures and the possible damage which may result, no user repairs are allowed. Evidence that an attempt has been made to open the optical head will void the manufacturer's warranty.

RFJ 0x0 Standard Version

Connection Summary

<u>Signal</u>	<u>Type</u>	<u>Connector</u>
Digital Modulation / -GATE TTL low (<0.8V) = ON TTL high (>2.5V) = OFF or no connection = OFF	Input	D Mod , SMA
Analogue Modulation* 0.0V(off) to 1.0V(on)	Input	A Mod , SMA
Interlock (connect to AO modulator 'INT')	Input	INT , Binder 719-3 Signal pin 1 Return pin 2

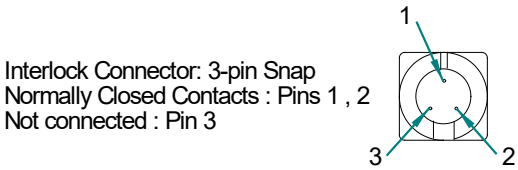

Notes:

Both D Mod and A Mod signals need to be applied.
The interlock must be connected. Contacts closed for normal operation.

* **A Mod** input voltage is model dependent 0-1V standard, Options -V = 0-5V, -X = 0-10V

5.0

Mounting.

4 off 4.2mm diameter holes on 190mm x 60mm centre spacing

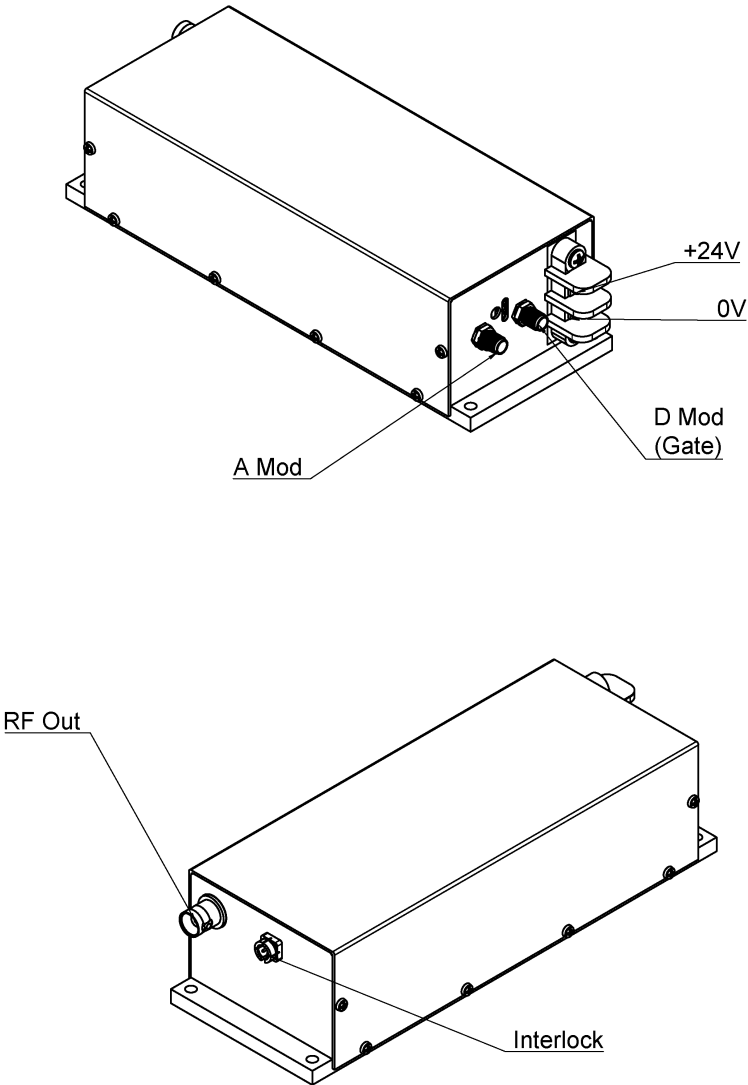

Figure 1: Driver Installation

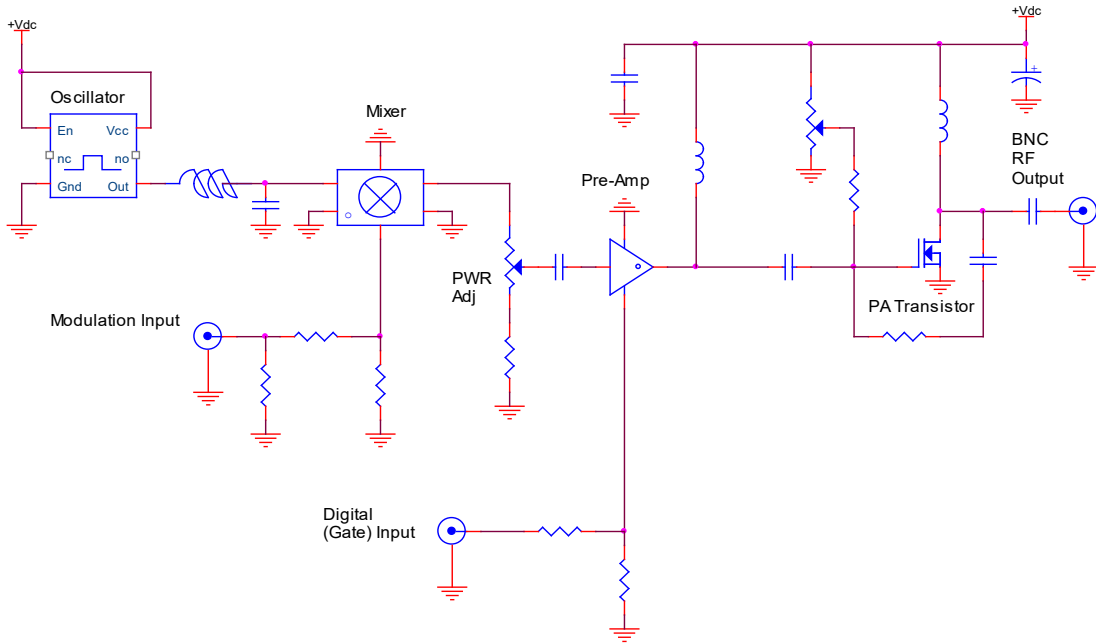
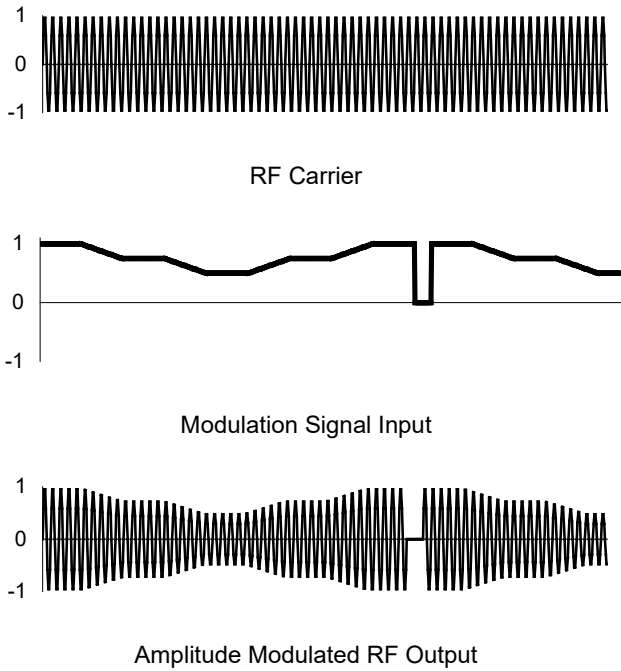

Figure 2: Driver Block Diagram

Analog modulation of an RF carrier.



RF amplitude modulation input is a combination of analog and digital control signals as illustrated below.

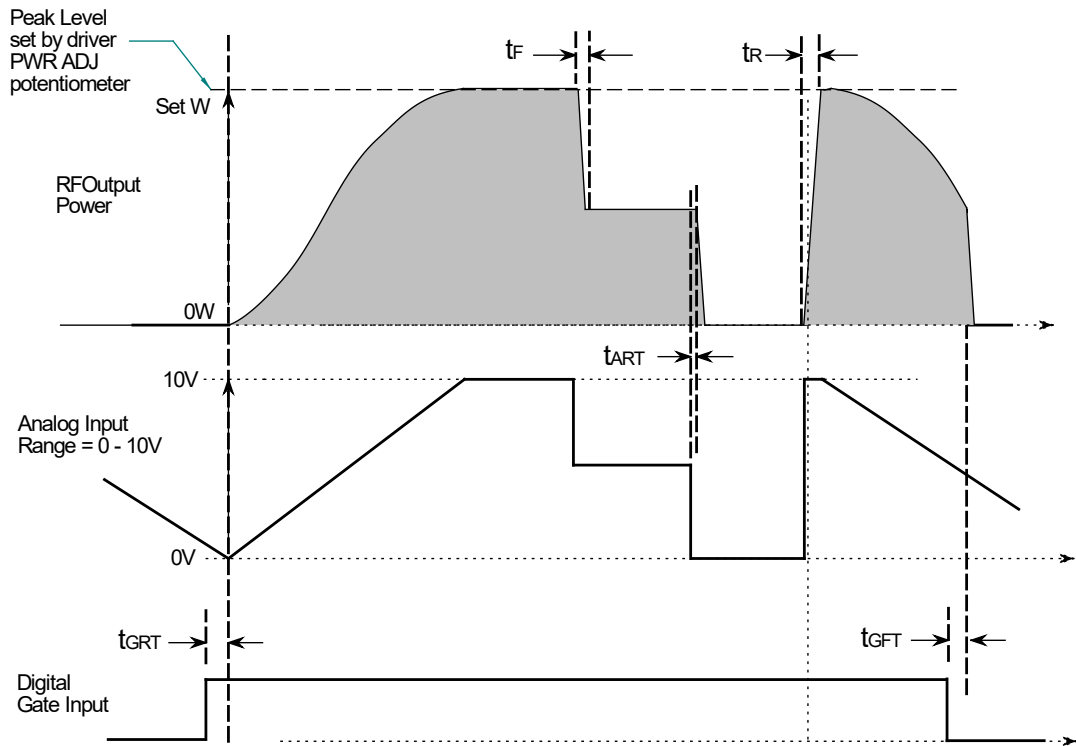

Figure 3: Typical Analog Modulation Waveforms

RF output timing spec's, refer Figure 3:

Ident	Description	Max
tR	RF rise time resulting from 'large signal' modulation	150 ns
tF	RF fall time resulting from 'large signal' modulation	50 ns
tART	Delay between a change in analog modulation input and change in RF output	< 10 ns
tGRT	Delay between a change in Digital / Gate input and RF output	< 10 ns
tGFT	Delay between a change in Digital / Gate input and RF output	< 10 ns

Orientation options

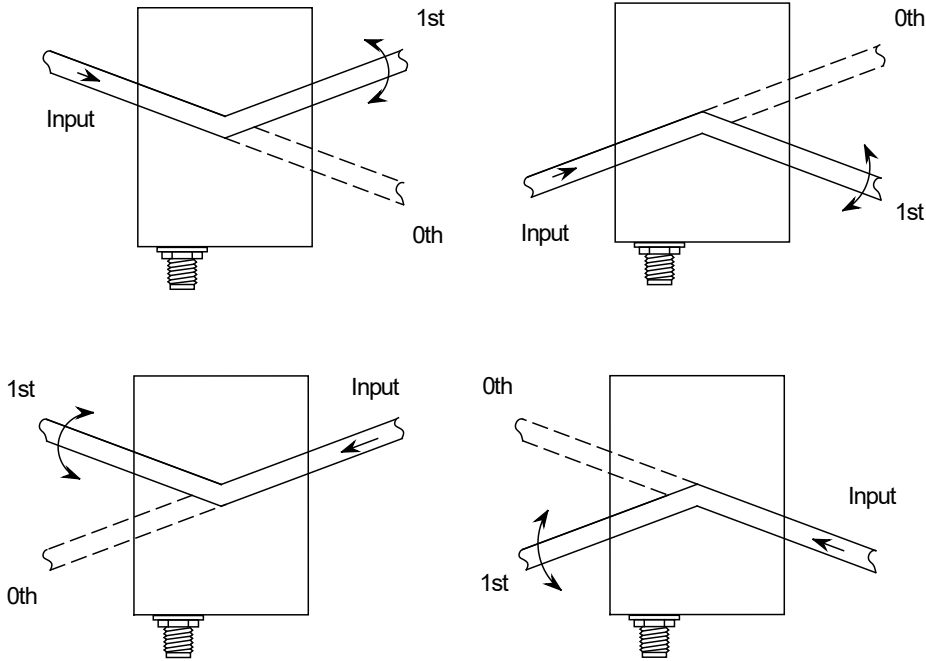
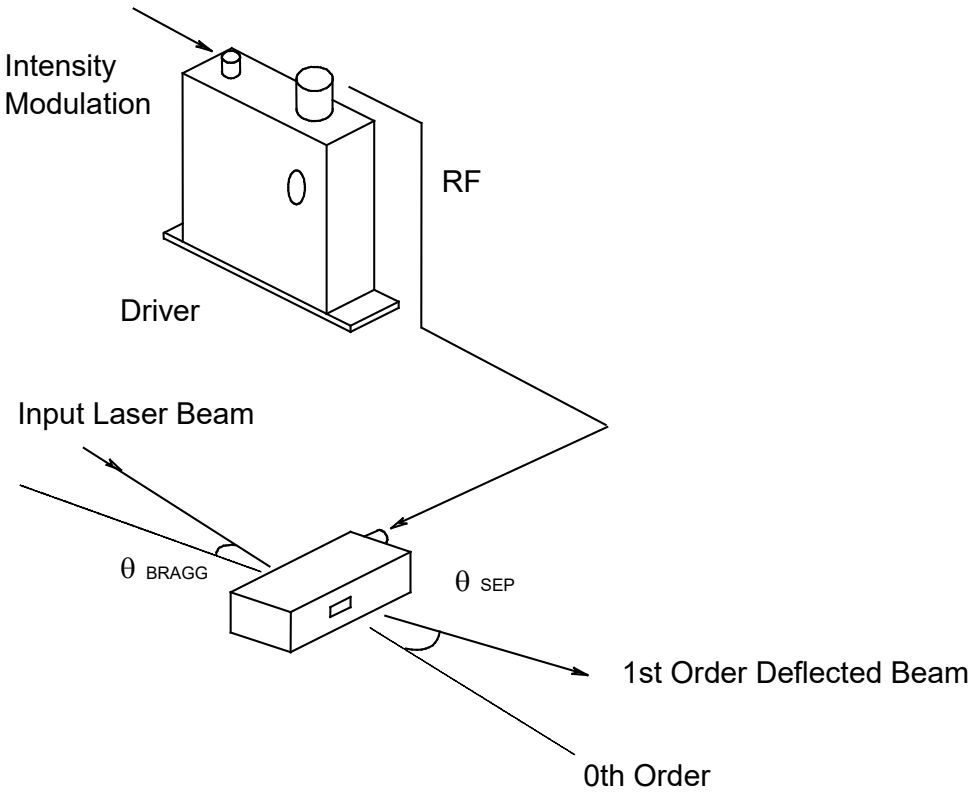

Figure 4: AO modulator orientations

Basic AO Modulator Parameters



The input Bragg angle, relative to a normal to the optical surface and in the plane of deflection is:

$$\theta_{BRAGG} = \frac{\lambda \cdot f_c}{2 \cdot v}$$

The separation angle between the Zeroth order and the First order is:

$$\theta_{SEP} = \frac{\lambda \cdot f_c}{v}$$

Optical rise time for a Gaussian input beam is approximately:

$$t_r = \frac{0.65 \cdot d}{v}$$

- where:
- λ = wavelength
 - f_c = centre frequency = 40MHz / 50MHz / 80MHz
 - v = acoustic velocity of interaction material = 5.7mm/usec (Quartz)
= 3.6mm/usec (Dense Flint Glass)

$d = 1/e^2$ beam diameter

Figure 5. Modulation Parameters

Appendix A: Beam Position

Timing and delay considerations

When attempting to synchronize a pulsed laser beam with a pulsed RF acoustic wave in an AO device, the designer must consider the transit time of the acoustic wave from the transducer to the laser beam position. This is called the Pedestal delay.

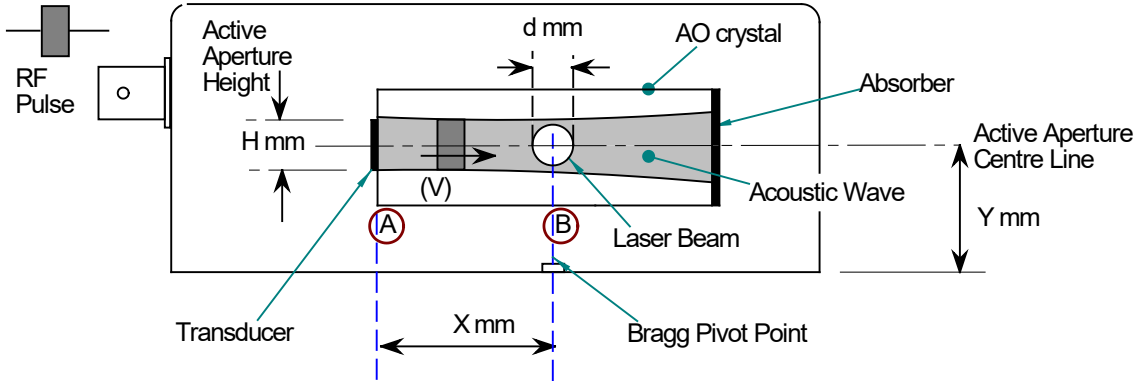

Input Beam Location

Vertical axis: Place the laser beam at the centre of the active aperture at Ymm above the base.
 Horizontal (Diffraction) axis : Place beam above the Bragg pivot point.

Timing considerations with respect to the RF modulation signal:

Acousto-optics are travelling wave devices. The acoustic wave is launched from the transducer and travels at velocity V across the laser beam and into the absorber.

- 1: Pedestal delay = time for the acoustic wavefront to reach the laser beam.
 $T_p = \text{beam position from transducer (X)} / \text{acoustic velocity (V)}$

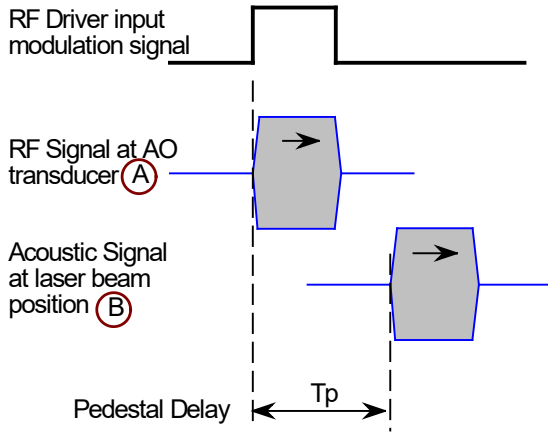

- 2: Transit time = time for the acoustic wavefront to cross the laser beam.
 $T_t = \text{beam diameter (d)} / \text{acoustic velocity (V)}$
 Optical switching time for a Gaussian beam is approximately $0.65 \times T_t$

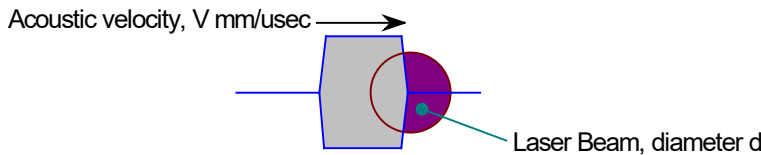

Example: M1133/M1377-aQ series Quartz AO modulators

The Acoustic velocity in Quartz is 5.7 mm/usec

The pedestal delay depends the laser beam position relative to the transducer.

Thus, for a laser beam placed 2mm from transducer face

$$\text{Pedestal delay} = 0.35 \text{ usec}$$

For an 1mm input beam diameter,

$$\text{Transit time} = 0.175 \text{ usec}$$

(Note: The optical rise time for a Gaussian beam is approximated by $0.65 \times$ transit time)

Laser synchronization

Please be aware, depending on the Laser type, there may be a significant delay between the laser input trigger signal and the actual laser optical output pulse.

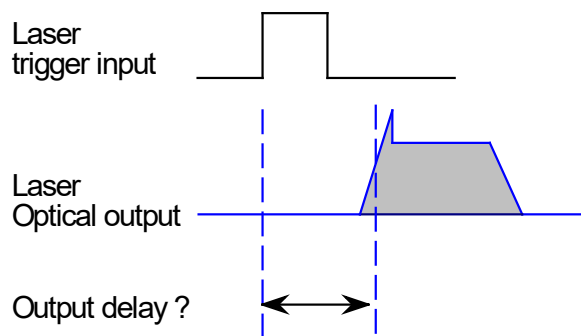

This should be considered when synchronizing the laser and pulsed RF (acoustic) waves.